

WARNING: THESE INSTRUCTIONS APPLY ONLY TO MODELS FAL7, FAL8 AND FAL9

1- Process

Dry off the area with a towel. Be sure to remove all water completely, as any moisture can cause problems.

Squeeze the trigger as evenly and steadily as possible. Drag the tube nozzle slowly along the seam of the surface.

Spread the sealant evenly. Protect your finger with a plastic or rubber bag. Wet your protected finger, and have a container of water nearby.

Use your finger to spread the sealant evenly. Keep getting your finger wet as you work.

2- Areas to be sealed

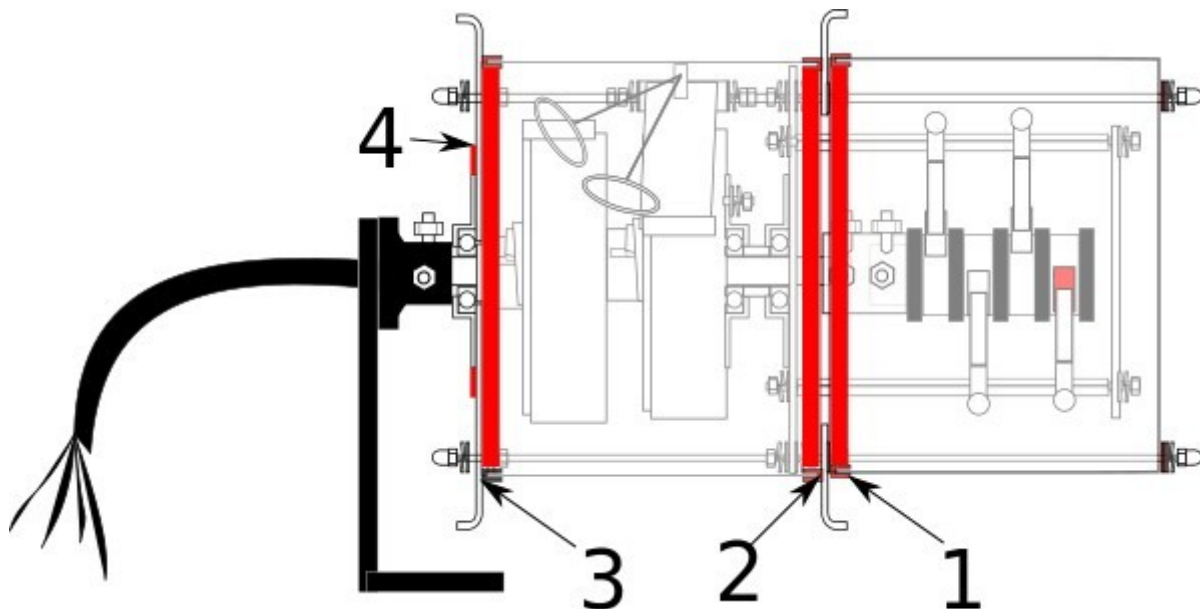

1- Following the rubber that seals the pot with the reel's wing 2 & 3- Following the rubber that seals the wings of the reel to the central body.

2-Models prior to 2019 do not have an O-ring on the outer bearing, so the bearing bracket must be sealed.